



# MD

Specialty Self-Contained, Multi-Deck  
Medium Temperature Merchandiser

# Specialty Self-Contained, Multi-Deck Merchandiser for Beverage, Dairy, Deli, and Produce Applications

## MD-10 and MD-14 - Specialty Multi-Deck Merchandiser

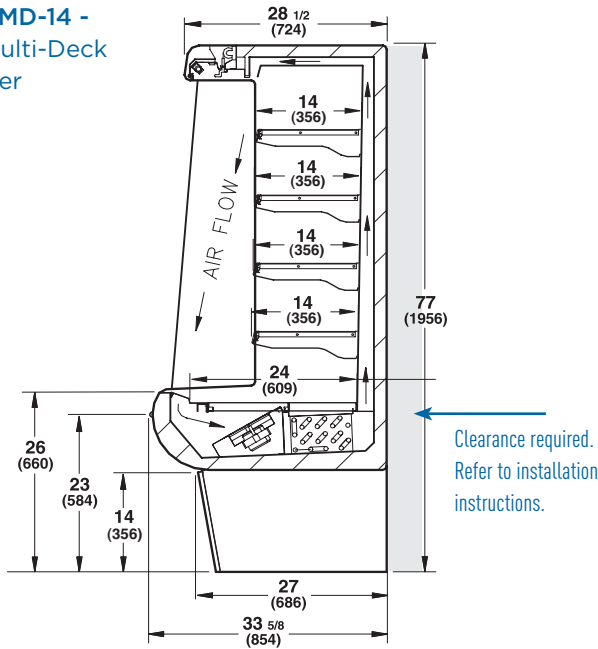

### Plan View

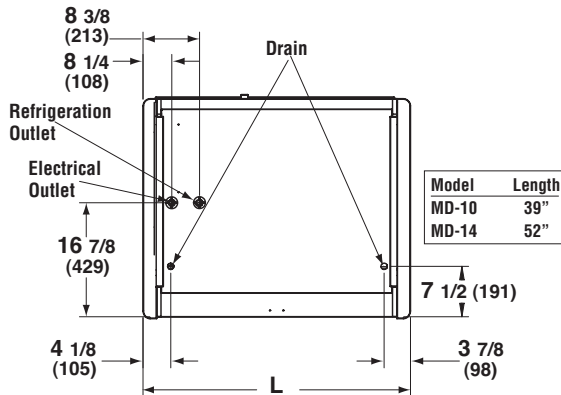

### Specifications

Model	Exterior Dimensions			Nom. HP	Refrig.	Electrical			Approx. Ship Wt. (lbs)	
	L	D	H			Volts	Run Amps	Fuse Amps		NEMA Plug
MD-10	39"	33-5/8"	77"	3/4	R-134a	208-230/60/1	10.3	15	6-15P	368
MD-14	52"	33-5/8"	77"	1	R-134a	208-230/60/1	12.0	15	6-15P	467

MD-10 Refrigeration load - 4813 BTU/h @ 20° F evaporation temperature and 110° F condensing temperature. AC load - 6201 BTU/h

MD-14 Refrigeration load - 7376 BTU/h @ 20° F evaporation temperature and 110° F condensing temperature. AC load - 9439 BTU/h



Hussmann refrigerated merchandisers configured for sale for use in the United States meet or surpass the requirements of the DOE 2012 energy efficiency standards.

### Advanced Design.

- Small footprint, high volume.
- Full front accessibility to products.
- Plexiglass ends for side visibility.
- White exterior upper body and black lower base section.
- All white powder coated paint.
- Standard red front bumper.
- All models ship from the factory with power cord connected NEMA 6-15 plugs.

### Merchandising with Style.

- Four 14-inch shelves adjustable to various positions.
- Shelves can be slanted for display appeal.
- Large bottom deck easily displays large, bulk impulse products.
- Upper canopy light provides full illumination of case interior.
- Built-in shelf PTM assists with unit pricing.

### Smart Construction.

- Durable molded plastic case ends that resist scratching and dents.
- Ends are foam insulated for superior operating efficiency.
- Off time defrost ensures maximum operating efficiency.
- Built-in electric condensate pan eliminates the need for external floor drains.
- Integrated night cover.
- Flow through panels provide maximum condensing unit ventilation.

### Innovative Refrigeration.

- Electronic controller maintains even case temperatures.

### Optional Accessories.

- Extra mezzanine shelf.
- Product stop.

NOTE: These merchandisers are designed for use in stores when temperature and humidity do not exceed 75° F and 55% R.H. Case is designed for holding pre-chilled product only.

NOTE: We reserve the right to change or revise specifications and product design in connection with any feature of our products. Such changes do not entitle the buyer to corresponding changes, improvements, additions, or replacements for equipment previously sold or shipped.

For additional resources and warranties, contact your representative or visit [www.hussmann.com](http://www.hussmann.com).



**Hussmann Corporation**  
12999 St. Charles Rock Rd.  
Bridgeton, MO 63044-2483  
Ph: 314.291.2000

[www.hussmann.com](http://www.hussmann.com)