



---

## ISFGG

Single-Deck Island, Self-Contained Low Temperature Merchandiser with Straight Glass on All Four Sides

# Single-Deck Island, Self-Contained Merchandiser for Frozen Food Applications

## ISFGG - Single-Deck, Low Temp Merchandiser

ISFGG-5/10



NEMA 6-20P

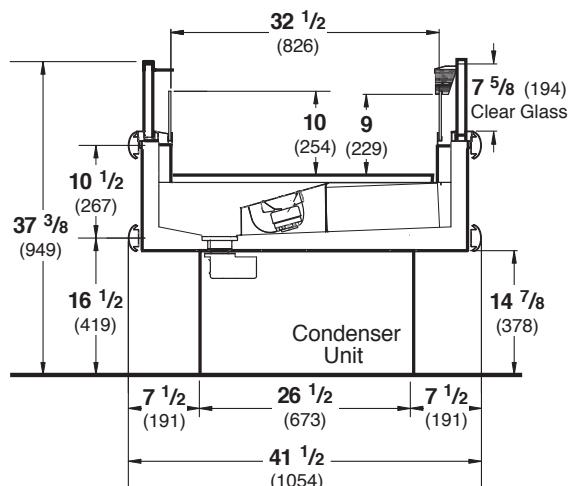

## Plan View

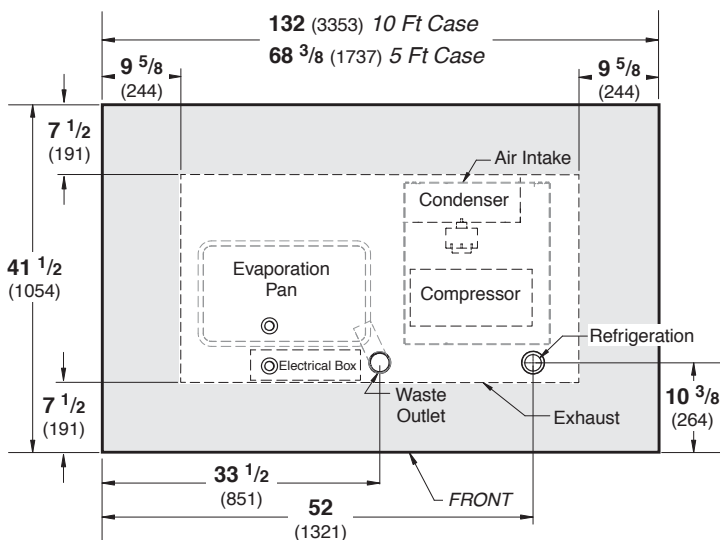

Note: Each 5-foot case section has a full 60-inch of interior length for product display.

## Advanced Design.

- White powder coated interior painting.
- Black upper and lower impact bumpers.
- Telescoping bottom wire selves.

## Smart Construction.

- One-inch dial thermometer.
- Electronic controls with digital display.
- Condensate pan.
- Expansion valve with filter kit.

## Innovative Refrigeration.

- R-404a refrigerant.
- Adjustable temperature control.
- Type II (80°F and 55% R.H.) certified.

## Optional Accessories.

- Dual-temperature kit changes merchandiser to medium temperature and is available on frozen food model.
- Variety of color options for bumper and décor panels.
- Stainless steel exterior.
- High humidity condensate pan kit.
- Price tag molding.
- Duplex receptacle kit.
- Recessed caster kit (factory installed).
- Two-inch dial thermometer.
- Degree Celsius control for thermometer.

## Specifications

Model	Exterior Dimensions				Nom. HP		Refrig.	Electrical				Approx. Ship Wt. (lbs)	
	5ft. L	10ft. L	D	H	5ft.	10ft.		H/Ph	Volts	Run Amps 5ft. 10ft.	Fuse Amps 5ft. 10ft.	NEMA Plugs 5ft. 10ft.	5ft. 10ft.
ISFGG-5D/G-10D/G	68-3/8"	132"	41-1/2"	37-3/8"	1	1HPx2	R-404a	60/1	208-230	15.7 15.7x2	20 20x2	6-20P 6-20Px2	670 1340

Note: All 10' models have two separate refrigeration systems and the self-contained models have 2 separated power cords.

### ISFGG-5 D/G -

Refrigeration load - 4280 BTU/h at -30°F evaporation temperature and 110°F condensing temperature AC load - 8773 BTU/h.

For 10 ft. cases, multiply the numbers by 2.



Type II

NOTE: These merchandisers are designed for use in stores when temperature and humidity do not exceed 80°F and 55% R.H.

NOTE: We reserve the right to change or revise specifications and product design in connection with any feature of our products. Such changes do not entitle the buyer to corresponding changes, improvements, additions, or replacements for equipment previously sold or shipped.

For additional resources and warranties, contact your representative or visit [www.hussmann.com](http://www.hussmann.com).



Hussmann refrigerated merchandisers configured for sale for use in the United States meet or surpass the requirements of the DOE 2012 energy efficiency standards.

# HUSSMANN®

**Hussmann Corporation**  
12999 St. Charles Rock Rd.  
Bridgeton, MO 63044-2483  
Ph: 314.291.2000

[www.hussmann.com](http://www.hussmann.com)