

HUSSMANN®

For a matching side-by-side display of dairy, deli, beverages and wine, be sure to see the companion HGL-TS series of low temperature 1-, 2- and 3-door models.



HGM-TS

Vertical, Top Mount, Self-Contained
Medium Temperature Merchandiser

- Hinged Glass Door

Vertical, Top Mount Self-Contained Merchandiser for Beverage, Dairy, and Deli Applications

HGM-1TS, HGM-2TS, HGM-3TS - Top Mount, Med Temp Glass Door Merchandiser

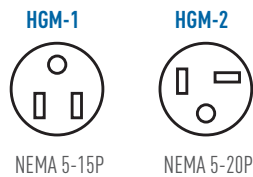
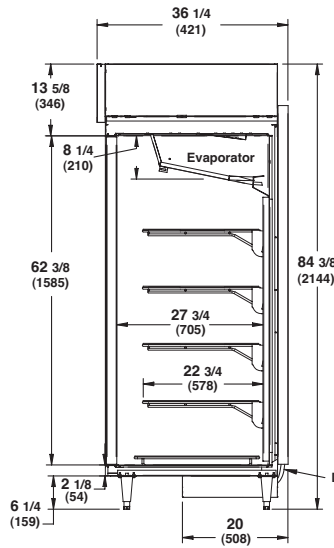

Specifications

Model	Exterior Dimensions		
	L	D*	H
HGM-1TS	28-7/8"	36-1/4"	84-3/8"
**HGM-1T	28-7/8"	36-1/4"	84-3/8"
HGM-2TS	52"	36-1/4"	84-3/8"
**HGM-2T	52"	36-1/4"	84-3/8"
HGM-3TS	75-3/8"	36-1/4"	84-3/8"
**HGM-3T	75-3/8"	36-1/4"	84-3/8"

Electrical

Model	Nom. HP	Refrig.	Hz/Ph	Volts	Run Amps	Fuse Amps	NEMA Plugs	Refrig. Load (BTU/h)	A/C Load (BTU/h)	Energy Consumption (kWh/day)	Approx. Ship Wt. (lbs)
HGM-1TS	1/3	R-134a	60/1	115	11.8	15	5-15P	1870	2575	5.46	562
**HGM-1T	-	R-134a	60/1	115	5.3	15	Hardwired	1870	-	-	489
HGM-2TS	1/2	R-134a	60/1	115	12.5	20	5-20P	2300	3165	8.96	776
**HGM-2T	-	R-134a	60/1	115	6.0	15	Hardwired	2300	-	-	681
HGM-3TS	3/4	R-134a	60/1	115	20.5	30	Hardwired	4270	5875	9.84	1050
**HGM-3T	-	R-134a	60/1	115	8.0	15	Hardwired	4270	-	-	945

* Exclusive of door handles.

** Remote version requires floor drain.



Hussmann refrigerated merchandisers configured for sale for use in the United States meet or surpass the requirements of the DOE 2012 energy efficiency standards.



Plan Views

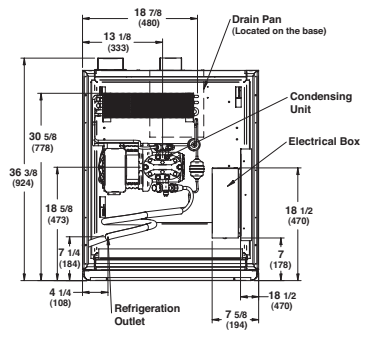

HGM-1TS

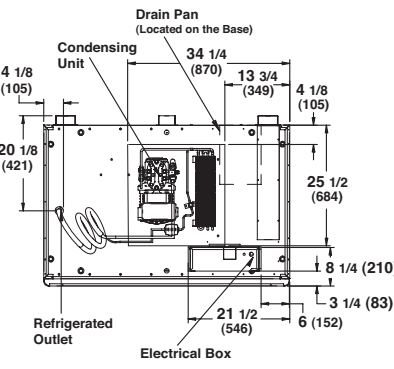

HGM-2TS

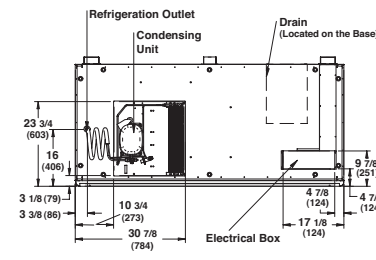

HGM-3TS

Advanced Design.

- Contemporary styling places maximum attention on merchandising.
- All HGM merchandisers have the same access panel design for commonality between merchandisers.
- White powder-coated exterior and interior finish.

Merchandising with Style.

- Polished silver door/frame standard.
- Improved product visibility, evenly illuminated merchandise, and energy savings with LED lighting.
- More lights per merchandiser with two lights in single-door, three-lights in two-door and four lights in three-door models.
- Each door section includes four adjustable cantilever-type shelves and a bottom rack.
- White epoxy-coated Shelves may be slanted for special displays and are interchangeable in all models.
- Full use of the shelf upright posts is available for positioning to better facilitate product merchandising under and across the shelves.

Smart Construction.

- Doors can be locked open for stocking.
- Ends are foam insulated for superior operating efficiency.
- The HGM-1TS and HGM-2TS are equipped with 115 volt power cord (see diagram).
- The HGM-3TS requires field wiring to 115 volt service.
- Each cabinet furnished with 6" adjustable legs.

Innovative Refrigeration.

- Easy-to-read digital solar powered thermometer.
- Electronic temperature control ensures consistent product temperature.

Optional Accessories.

- Variety of exterior colors.
- Three-tier step rack, additional display shelves available.
- Price tag molding.
- Baskets, peg bar and hooks.
- Door guard, shelf product stops, and skirt kits.
- Lighted signage.
- Door locks.
- Can dispensing rack.

NOTE: These merchandisers are designed for use in stores when temperature and humidity do not exceed 75°F and 55% R.H. Case is designed for holding pre-chilled product only.

NOTE: We reserve the right to change or revise specifications and product design in connection with any feature of our products. Such changes do not entitle the buyer to corresponding changes, improvements, additions, or replacements for equipment previously sold or shipped.

For additional resources and warranties, contact your representative or visit www.hussmann.com.

Hussmann Corporation
12999 St. Charles Rock Rd.
Bridgeton, MO 63044-2483
Ph: 314.291.2000

www.hussmann.com

HUSSMANN®