

**HUSSMANN®**

---



## DDSS-4MC

High Capacity, Self-Contained Multi-Deck  
Medium Temperature Merchandiser

- 29-Inch Deep Footprint

---

[www.hussmann.com](http://www.hussmann.com)

# High Capacity, Self-Contained Multi-Deck Merchandiser for Beverage, Salad, and Sandwich Applications

## DDSS-4MC - High Capacity Multi-Deck Merchandiser

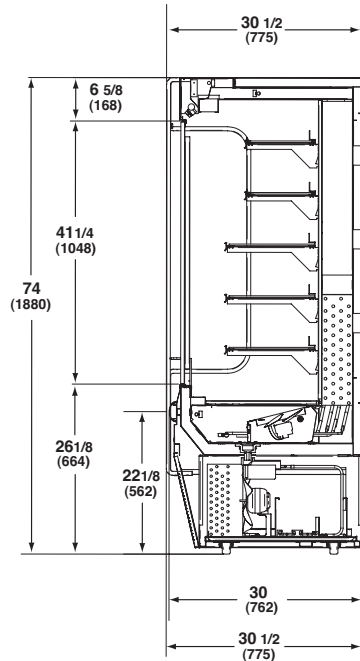

NEMA 6-20P

## Plan View

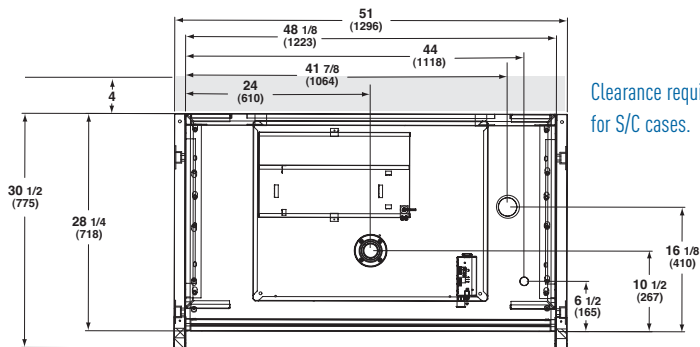

Clearance required for S/C cases.

## Advanced Design.

- Maximum capacity in a 29-inch deep footprint.
- Glass shelves (3) 13-inch and (2) 9-3/4-inch, with silver PTM.
- White interior and exterior.
- Black front bumper.
- Solid ends.

## Merchandising with Style.

- Newly designed access panel.
- Lighted sign.

## Smart Construction.

- R-404A condensing unit (208/230V, 20A, cord connected).
- One row upper canopy light (T-8).
- Low profile casters.

## Innovative Refrigeration.

- Type II (80°F and 55% R.H.) certified.
- Electronic controls with digital display.

## Optional Accessories.

- Integrated night cover.
- Reversing condenser fan motor.
- Locking security cover.
- Leg kit.
- View ends.
- Mirror interior.
- Stainless steel exterior.
- 6-inch casters.
- Solid shelves (12-inch and 10-inch).
- Black or white PTM.
- Reversing product stop.

## Specifications

Model	Exterior Dimensions			Nom. HP	Refrig.	Electrical			NEMA Plug	Approx. Ship Wt. (lbs)	
	L	D	H			Hertz/Ph	Volts	Run Amps			Fuse Amps
DDSS-4MC	51"	30-1/2"	74"	3/4	R-404a	60/1	208-230	10.85	20	6-20P	900
DDSS-4MCR	51"	30-1/2"	74"	NA	R-404a	60/1	208-230	0.60	15	NA*	850

Refrigeration load requirement: 6402 BTU/h @ 15°F evaporating, 110°F condensing temperature AC load requirement: 8623 BTU/h.

\* Field hardwired.



Type II

NOTE: These merchandisers are designed for use in stores when temperature and humidity do not exceed 80°F and 55% R.H. Case is designed for holding pre-chilled product only.

NOTE: We reserve the right to change or revise specifications and product design in connection with any feature of our products. Such changes do not entitle the buyer to corresponding changes, improvements, additions, or replacements for equipment previously sold or shipped.

For additional resources and warranties, contact your representative or visit [www.hussmann.com](http://www.hussmann.com).



Hussmann refrigerated merchandisers configured for sale for use in the United States meet or surpass the requirements of the DOE 2012 energy efficiency standards.

# HUSSMANN®

**Hussmann Corporation**  
12999 St. Charles Rock Rd.  
Bridgeton, MO 63044-2483  
Ph: 314.291.2000

[www.hussmann.com](http://www.hussmann.com)