



Microchannel

REMOTE AIR COOLED CONDENSER

Technical Bulletin



Products that provide lasting solutions.

Microchannel Remote Air Cooled Condenser



**Krack Corporation
has a long tradition
of leadership and
product innovation
in the commercial
and industrial
refrigeration
industries.**

Krack's new Microchannel Remote Air Cooled Condenser incorporates a new patented modular assembly.

- Smaller size and less weight reduces cost in the building construction.
- The new coil has less internal volume resulting in a significant reduction in refrigerant charge. Less refrigerant is environmentally friendly.
- Electronic head pressure/coil reduction controls reduce or eliminate winter flooding charge.
- Coil slabs are easily replaced from the rear of the unit.

Environmentally Friendly Benefits

- **Reduced Coil Internal Volume** - Resulting in a significant reduction in condenser operating and flooding charge.
- **Electronic Head Pressure/Coil Reduction Controls (Patent Pending)** - Reduces or eliminates winter flooding charge on larger models.
- **Quiet Fans** - "Swept-wing" blade design offers lower noise levels at the same speed. Quiet multi-bladed direct driven propeller fans provide uniform air distribution through the coil. Venturi fan orifices optimize efficiency. Lower noise condensers can translate into savings by minimizing the need for costly noise barriers.

Progress is greener
with Ingersoll Rand

Table of Contents

Features and Benefits	1
System Selections	2
Model Key	2
Applications	3
Performance Data	4
Electrical Data	5
Dimensional Data	5
Control System	9
Receiver Data	9
Control Panel Nomenclature	10
Condenser Control Panel	11
Replacement Parts	15

Microchannel Remote Air Cooled Condenser

Features and Benefits

REMOTE AIR-COOLED CONDENSER

Patented Microchannel Condenser Modular Assembly Design (Patent #6988538)

- Arranged for vertical air discharge.
- Multi-fan sections compartmented to allow individual fan cycling while preventing off-fan “windmilling.”
- Removable end panel for clean out and service access.

Corrosion Resistant

- All models employ mill galvanized steel fan sections and coil side baffles.
- Legs are heavy mill gauge galvanized steel.
- Corrosion resistance is improved with the all aluminum microchannel coil, reducing the chance for galvanic corrosion that exists on traditional copper tube and aluminum fin coils. Additionally, the microchannel tubes are coated with a sacrificial metallic layer that is less noble than the tube, fin, and braze material.

PROTECTIVE COVER PANELS

Weather Resistant Fan Motors

- Outdoor condenser motors designed with ball bearings inherent overheat protection in each phase; shaft slingers; enclosure, hardware, and lubrication for all weather conditions.
- Each motor lead is wired to terminals in an electrical enclosure.

Versatile Fan Cycling Control Methods

- Temperature fan cycling.
- Electronic relay boards.
- Temperature and pressure fan cycling.
- Pressure fan cycling.
- Variable speed fans.

Replaceable High Efficiency Coil

- Extruded aluminum microchannel coil construction increases coil efficiency, while reducing refrigerant operating charge, unit weight and footprint.
- Unit design allows for coil replacement from rear of unit.

COMPACT DESIGN

- Lighter weight.
 - Up to 35% weight reduction compared to traditional condenser design.
- Ideal match for Hussmann Protocol systems.
- Modular construction and fewer parts.
 - Available in 2 to 14 fan models.

Modular Winter Reduction:

- Maintains condenser pressure by isolating coil sections in conjunction with fan cycling.
- Reduction in coil volume results in reduced refrigerant operating and flooding charge.

INVERTER READY MOTORS STANDARD

(Not Available in 575 RPM or 575 Volt)

OPTIONAL FEATURES

- Winter flooding control solenoids.
- Electro-Fin coated coils.
- Reusable air filter.
- Mounted receiver.



Microchannel Remote Air Cooled Condenser

System Selections

THR - Total Heat of Rejection

- Condenser total heat of rejection (BTU/h) is the sum of the evaporator refrigeration effect and the heat of compression which varies with compressor type and operating conditions.

THR Calculation Method

- THR = Open Reciprocating Compressor Capacity (BTU/h) + (2545 x BHP)
- THR = Suction Gas Cooled Hermetic Reciprocating Compressor Capacity (BTU/h) = (3413 x KW).

THR Estimated Method

- THR may be estimated by multiplying the rated compressor BTU/h capacity by the compressor operating condition factor shown in Table 1 or 2. Multiply result by altitude factor when applicable.

Model Key

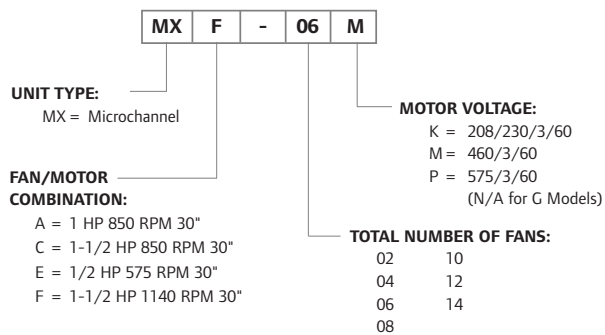

TABLE 1

EVAPORATOR TEMP (°F)	HERMETIC COMPRESSOR					
	CONDENSING TEMPERATURE (°F)					
	90	100	110	120	130	140
-40	1.66	1.73	1.80	2.00	*	*
-30	1.57	1.62	1.68	1.80	*	*
-20	1.49	1.53	1.58	1.65	*	*
-10	1.42	1.46	1.50	1.57	1.64	*
0	1.36	1.40	1.44	1.50	1.56	1.62
5	1.33	1.37	1.41	1.46	1.52	1.59
10	1.31	1.34	1.38	1.43	1.49	1.55
15	1.28	1.32	1.35	1.40	1.46	1.52
20	1.26	1.29	1.33	1.37	1.43	1.49
25	1.24	1.27	1.31	1.35	1.40	1.45
30	1.22	1.25	1.28	1.32	1.37	1.42
40	1.18	1.21	1.24	1.27	1.31	1.35
50	1.14	1.17	1.20	1.23	1.26	1.29

*Beyond the normal limits for single stage compressor application.

TABLE 2

EVAPORATOR TEMP (°F)	OPEN COMPRESSOR					
	CONDENSING TEMPERATURE (°F)					
	90	100	110	120	130	140
-30	1.37	1.42	1.47	*	*	*
-20	1.33	1.37	1.42	1.47	*	*
-10	1.28	1.32	1.37	1.42	1.47	*
0	1.24	1.28	1.32	1.37	1.41	1.47
10	1.21	1.24	1.28	1.32	1.36	1.42
20	1.17	1.20	1.24	1.28	1.32	1.37
30	1.14	1.17	1.20	1.24	1.27	1.32
40	1.12	1.15	1.17	1.20	1.23	1.28
50	1.09	1.12	1.14	1.17	1.20	1.24

*Beyond the normal limits for single stage compressor application.

TABLE 3

ALTITUDE			
FEET	FACTOR	FEET	FACTOR
1,000	1.02	5,000	1.12
2,000	1.05	6,000	1.15
3,000	1.07	7,000	1.17
4,000	1.10	8,000	1.24

Microchannel Remote Air Cooled Condenser

Applications

- **Locate Condensers** no closer than their width from walls or other condensers. Avoid locations near exhaust fans, plumbing vents, flues or chimneys.
- **Parallel Condensers** should be the same model resulting in the same refrigerant side pressure drops. Compressor discharge lines should have equal pressure drops to each condenser.
- **Condenser Refrigerant Charge** for Summer conditions are listed on the Performance Data Table. The additional Winter Flooding charge required is difficult to predict with fan cycling and is maximized with holdback; however, the maximum additional refrigerant charge is also listed on the Performance Data Table for Winter conditions at -20°F. The Summer operating and Winter maximum flooding charge is substantially less than that required for traditional tube and fin condensers due to the reduced internal volume of the microchannel coils. Further reduction in flooding charge can be obtained with the “Modular Winter Reduction” option, by “shutting down” the associated refrigerant circuit in combination with fan cycling.
- **Receiver Capacity** should be sized to store condenser summer charge, plus the condenser low ambient allowance, plus the evaporator charge, plus an allowance for piping and heat reclaim coil charges.
- **Compressor Discharge** lines should be sized to minimize pressure drops and maintain oil return gas velocities. Each connection should be looped to the top of the condenser.
- **Gravity Liquid Drain Lines** should drop from each outlet as low as possible before headering or running horizontally. Pitch downhill to receiver.
- **Off-Line Coil Sections** will have refrigerant pressures corresponding to the ambient. Check valves or isolating valves should be installed in the liquid line drains to prevent refrigerant migration and receiver pressure loss.

REFRIGERANT LINE CAPACITY DATA

COPPER LINE SIZE O.D.	LINE CAPACITY IN TONS						LBS. OF REFRIGERANT LIQUID PER 100' OF LENGTH		
	COMPRESSOR DISCHARGE LINE			CONDENSER TO RECEIVER LIQUID LINE 100'			R-22	R-404A	R-134a
	R-22	R-404A	R-134a	R-22	R-404A	R-134a			
5/8	1.0	0.5	0.5	3.6	3.0	3.7	130.0	11.0	13.0
7/8	3.0	2.0	2.0	7.4	6.0	7.7	25.0	22.0	26.0
1-1/8	6.5	4.5	4.5	12.7	10.4	13.0	42.0	36.0	43.0
1-3/8	15.0	7.0	7.0	19.2	16.0	20.0	64.0	55.0	65.0
1-5/8	20.0	15.0	11.0	29.0	23.0	28.5	90.0	78.0	92.0
2-1/8	45.0	30.0	28.0	47.0	40.0	46.0	160.0	138.0	163.0
2-5/8	75.0	45.0	43.0	73.0	62.0	72.0	245.0	212.0	250.0

Capacity is compressor suction tons for application between -40°F and +40°F suction at condensing temperatures between 80°F and 120°F sat.

For multiple or unloading compressor application, the vertical discharge riser from the compressor may need to be one size smaller.

This table data is only to be used as a guide. For exact values, please calculate to your specific job line lengths and design pressure/temp values using ASHRAE handbook or ARI refrigerant tables.

Microchannel Remote Air Cooled Condenser

Performance Data

HP	RPM	MX MODEL	TOTAL HEAT OF REJECTION (MBH)						AIR FLOW (CFM)	SOUND dBA EST @10 FT	SUMMER CHARGE (LBS R-404A)	WINTER CHARGE (LBS R-404A)	SHIP WEIGHT (LBS)
			R-404A/R-507			R-22							
			TEMP DIFFERENCE			TEMP DIFFERENCE							
			10°F	15°F	20°F	10°F	15°F	20°F					
0.5	575	MXE-02	98.8	148.2	197.6	100.8	151.2	201.6	12,600	55	4	12	560
		MXE-04	197.5	296.3	395.0	201.5	302.3	403.0	25,200	58	15	26	1,170
		MXE-06	296.3	444.5	592.6	302.3	453.5	604.6	37,800	60	23	40	1,705
		MXE-08	395.0	592.5	790.0	403.2	604.8	806.4	50,400	61	40	55	2,280
		MXE-10	493.8	740.7	987.6	504.0	756.0	1,008.0	63,000	62	52	70	2,850
		MXE-12	592.5	888.8	1,185.0	604.8	907.2	1,209.6	75,600	63	80	88	3,385
		MXE-14	691.3	1,037.0	1,382.6	705.6	1,058.4	1,411.2	88,200	64	108	106	3,920
1.0	850	MXA-02	145.2	217.8	290.4	148.1	222.2	296.2	20,800	66	4	12	560
		MXA-04	290.3	435.5	580.6	296.2	444.3	592.4	41,600	69	15	26	1,170
		MXA-06	435.5	653.3	871.0	444.3	666.5	888.6	62,400	71	23	40	1,705
		MXA-08	580.7	871.1	1,161.4	592.4	888.6	1,184.8	83,200	72	40	55	2,280
		MXA-10	725.8	1,088.7	1,451.6	740.5	1,110.8	1,481.0	104,000	73	52	70	2,850
		MXA-12	871.0	1,306.5	1,742.0	888.6	1,332.9	1,777.2	124,800	74	80	88	3,385
		MXA-14	1,016.2	1,524.3	2,032.4	1,036.7	1,555.1	2,073.4	145,600	75	108	106	3,920
1.5	850	MXC-02	151.8	227.7	303.6	154.9	232.4	309.8	22,830	68	4	12	560
		MXC-04	303.5	455.3	607.0	309.8	464.7	619.6	45,660	71	15	26	1,170
		MXC-06	455.3	683.0	910.6	464.7	697.1	929.4	68,490	73	23	40	1,705
		MXC-08	607.1	910.7	1,214.2	619.6	929.4	1,239.2	91,320	74	40	55	2,280
		MXC-10	758.8	1,138.2	1,517.6	774.5	1,161.8	1,549.0	114,150	75	52	70	2,850
		MXC-12	910.6	1,365.9	1,821.2	929.4	1,394.1	1,858.8	136,980	76	80	88	3,385
		MXC-14	1,062.4	1,593.6	2,124.8	1,084.3	1,626.5	2,168.6	159,010	77	108	106	3,920
1.5	1140	MXF-02	154.5	231.8	309.0	157.6	236.4	315.2	25,600	75	4	12	560
		MXF-04	308.9	463.4	617.8	315.2	472.8	630.4	51,200	78	15	26	1,170
		MXF-06	463.4	695.1	926.8	472.8	709.2	945.6	76,800	80	23	40	1,705
		MXF-08	617.8	926.7	1,235.6	630.4	945.6	1,260.8	102,400	81	40	55	2,280
		MXF-10	772.3	1,158.5	1,544.6	788.0	1,182.0	1,576.0	128,000	82	52	70	2,850
		MXF-12	926.7	1,390.1	1,853.4	945.6	1,418.4	1,891.2	153,600	83	80	88	3,385
		MXF-14	1,081.2	1,621.8	2,162.4	1,103.2	1,654.8	2,206.4	179,200	84	108	106	3,920

***NOTE:**

1. Additional winter flooding charge shown is without module isolation/reduction.
2. Ship weight includes "ship loose" leg weights.
3. Multiply summer operating charge by 1.14 for R-22.
4. Multiply winter flooding charge by 1.10 for R-22.
5. Sound data is an estimate only. It can be greatly affected by surroundings.

4 MICROCHANNEL REMOTE AIR COOLED CONDENSER

Specifications subject to change without notice.

Microchannel Remote Air Cooled Condenser

Electrical Data

MX MODEL	FAN MOTOR TOTAL FULL LOAD AMPS			MX MODEL	FAN MOTOR TOTAL FULL LOAD AMPS		
	208-230/3/60	460/3/60	575/3/60		208-230/3/60	460/3/60	575/3/60
MXE-02	6.8	3.4	2.4	MXC-02	12.0	6.0	5.0
MXE-04	13.6	6.8	4.8	MXC-04	24.0	12.0	10.0
MXE-06	20.4	10.2	7.2	MXC-06	36.0	18.0	15.0
MXE-08	27.2	13.6	9.6	MXC-08	48.0	24.0	20.0
MXE-10	34.0	17.0	12.0	MXC-10	60.0	30.0	25.0
MXE-12	40.8	20.4	14.4	MXC-12	72.0	36.0	30.0
MXE-14	47.6	23.8	16.8	MXC-14	84.0	42.0	35.0
MXA-02	8.8	4.0	2.9	MXF-02	14.0	7.0	4.8
MXA-04	17.6	8.0	5.8	MXF-04	28.0	14.0	9.6
MXA-06	26.4	12.0	8.7	MXF-06	42.0	21.0	14.4
MXA-08	35.2	16.0	11.6	MXF-08	56.0	28.0	19.2
MXA-10	44.0	20.0	14.5	MXF-10	70.0	35.0	24.0
MXA-12	52.8	24.0	17.4	MXF-12	84.0	42.0	28.8
MXA-14	61.6	28.0	20.3	MXF-14	98.0	49.0	33.6

Dimensional Data

DIMENSIONS (Inches)					
MODEL	L	W	H	HEIGHT WITH SHIP LOOSE LEGS	HEIGHT WITH MTD REC
MX()-02	44.0	90.25	42.0	64.0	60.0
MX()-04	88.0	90.25	42.0	64.0	60.0
MX()-06	132.0	90.25	42.0	64.0	60.0
MX()-08	176.0	90.25	42.0	64.0	60.0
MX()-10	220.0	90.25	42.0	64.0	60.0
MX()-12	264.0	90.25	42.0	64.0	60.0
MX()-14	308.0	90.25	42.0	64.0	60.0

Microchannel Remote Air Cooled Condenser

Dimensional Data - Standard Model

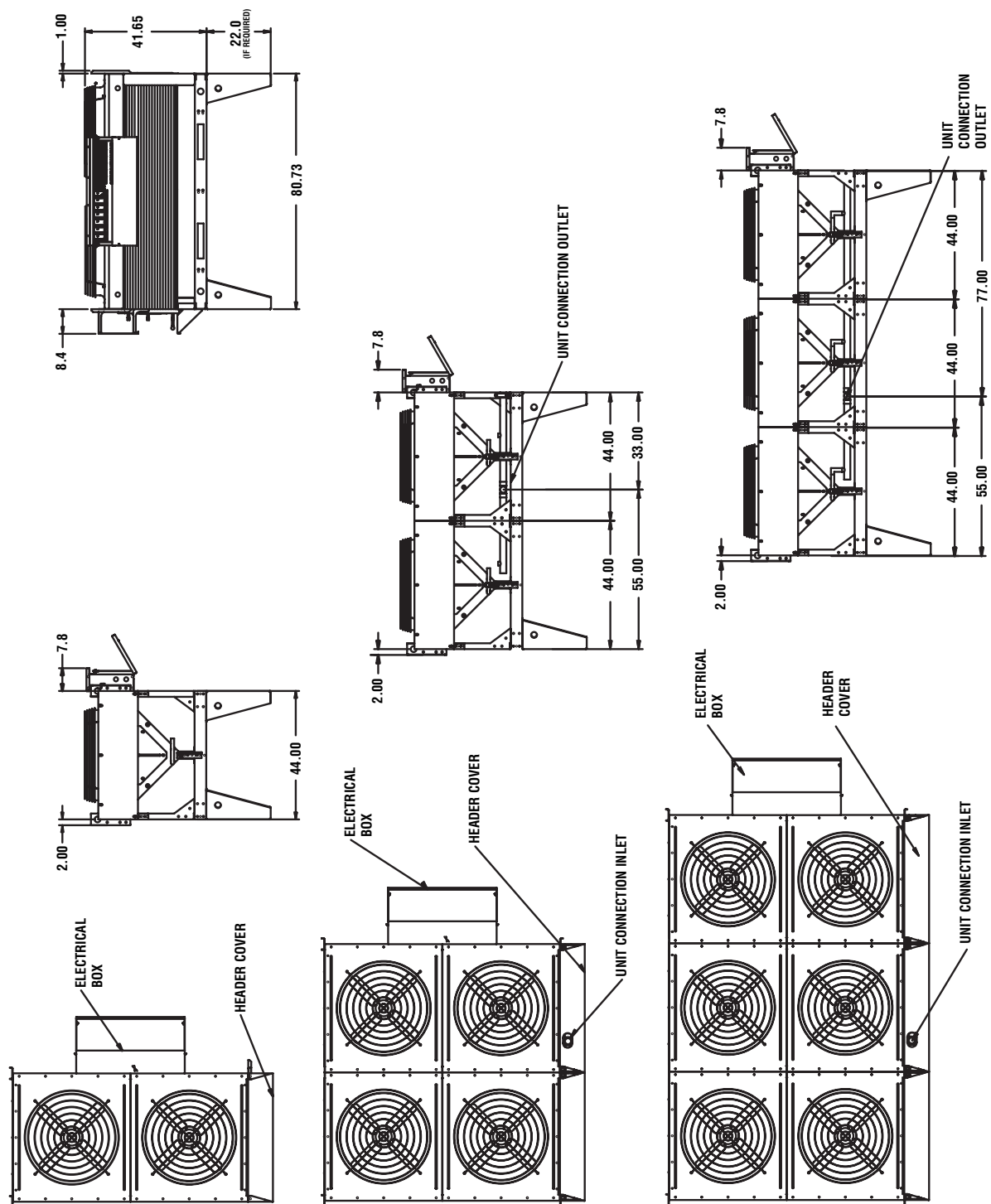

Microchannel Remote Air Cooled Condenser

Dimensional Data - Receiver Model

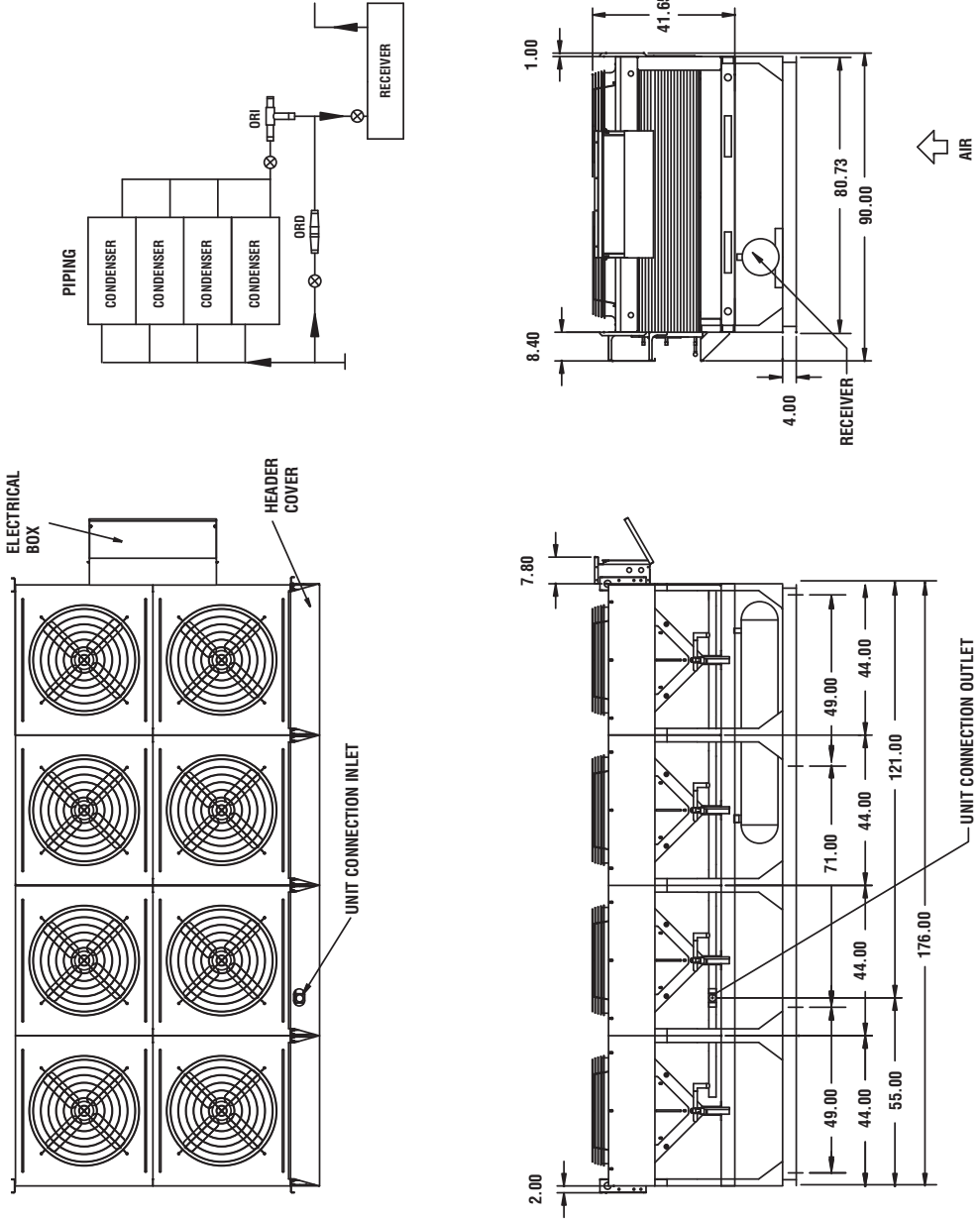

Microchannel Remote Air Cooled Condenser

Dimensional Data - Receiver Model (cont.)

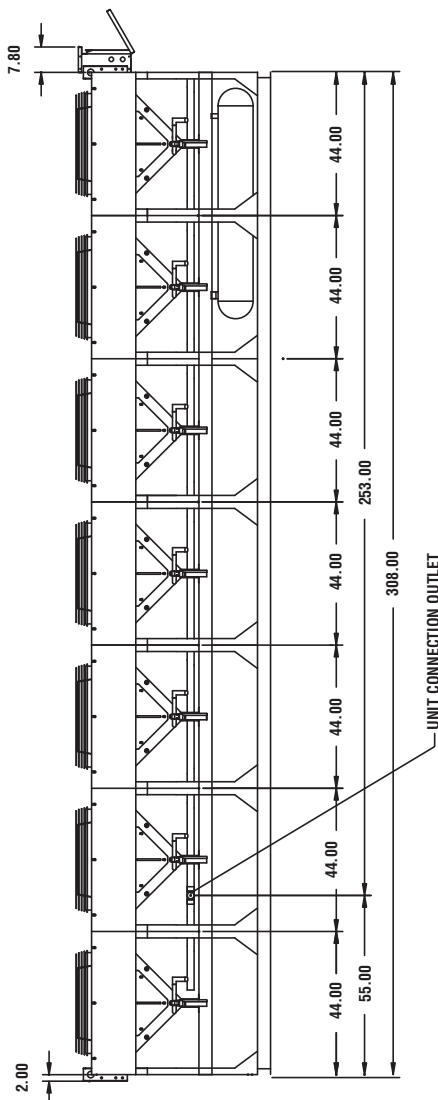
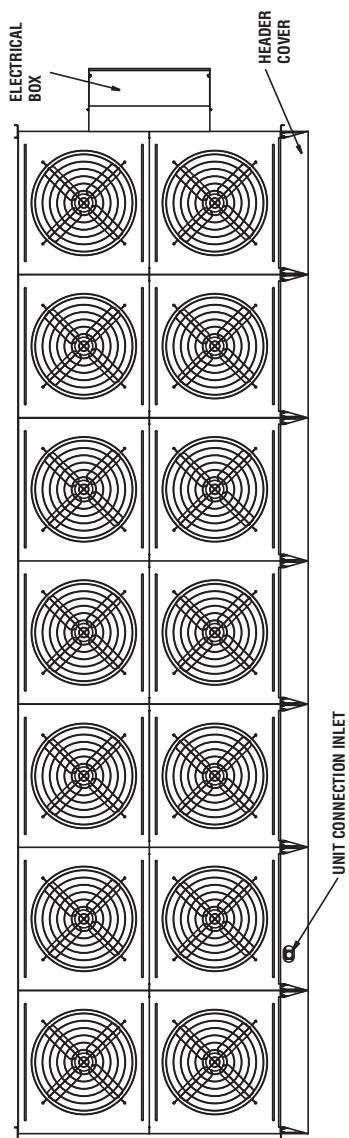
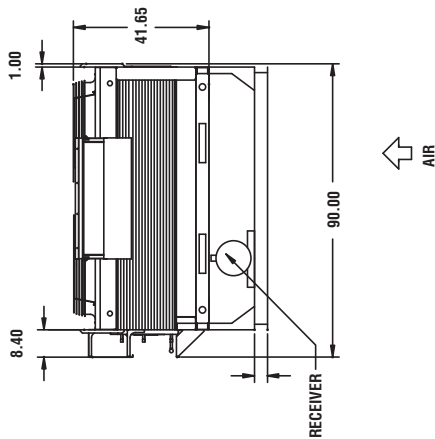
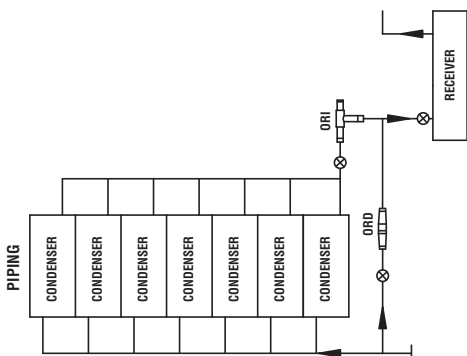

Microchannel Remote Air Cooled Condenser

Control System

Piping Schematic for Winter Control

Head pressure control for systems with air cooled condenser is accomplished with two pressure regulating valves designed specifically for this type of application. When low ambient conditions are encountered during winter operation on air cooled systems with a resultant drop in condensing pressure, the Head pressure control's purpose is to hold back enough of the condenser liquid refrigerant so that some of the condenser surface is rendered inactive. This reduction of active condensing surface results in a rise in the condensing pressure and sufficient liquid line pressure for normal system operation.

Modular Winter Reduction

Maintains condenser pressure by isolating coil sections in conjunction with fan cycling. Reduction in coil volume results in reduced refrigerant operating and flooding charge.

Fan Cycling Controls

Factory installed and tested fan cycling control panels (optional, see pages 12 - 15 for details).

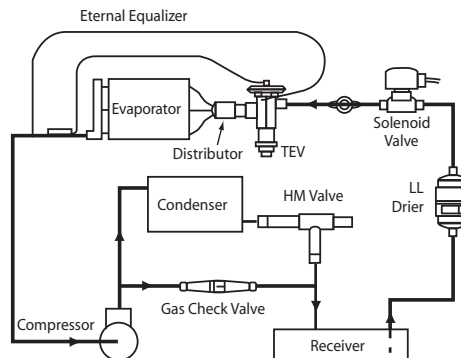

Receiver Data

Microchannel is available with a mounted receiver for applications where a remote receiver is desired. Included in the option are extended legs, receiver, 3-way valve, relief valve, rotalocks, ball valves, and ORI/ORD valves. Optional heated and/or oversized receivers available.

RECEIVER CAPACITIES

MODEL SIZE	R-22 (LBS)	R-404A / R-507 (LBS)
10.75" x 60"	192	167
12.75" x 72"	276	240

ADDITIONAL UNIT WEIGHT

NUMBER OF FANS	NUMBER OF RECEIVERS	
	1	2
2 x 2	290	-
2 x 3	360	550
2 x 4	440	620
2 x 5	600	900
2 x 6	680	980
2 x 7	750	1,050

CONNECTION SIZES

NUMBER OF FANS	INLET	OUTLET
2	1-3/8"	1-3/8"
4	1-3/8"	1-3/8"
6	2-1/8"	2-1/8"
8	2-1/8"	2-1/8"
10	2-5/8"	2-5/8"
12	3-1/8"	3-1/8"
14	3-1/8"	3-1/8"

Microchannel Remote Air Cooled Condenser

Control Panel Nomenclature

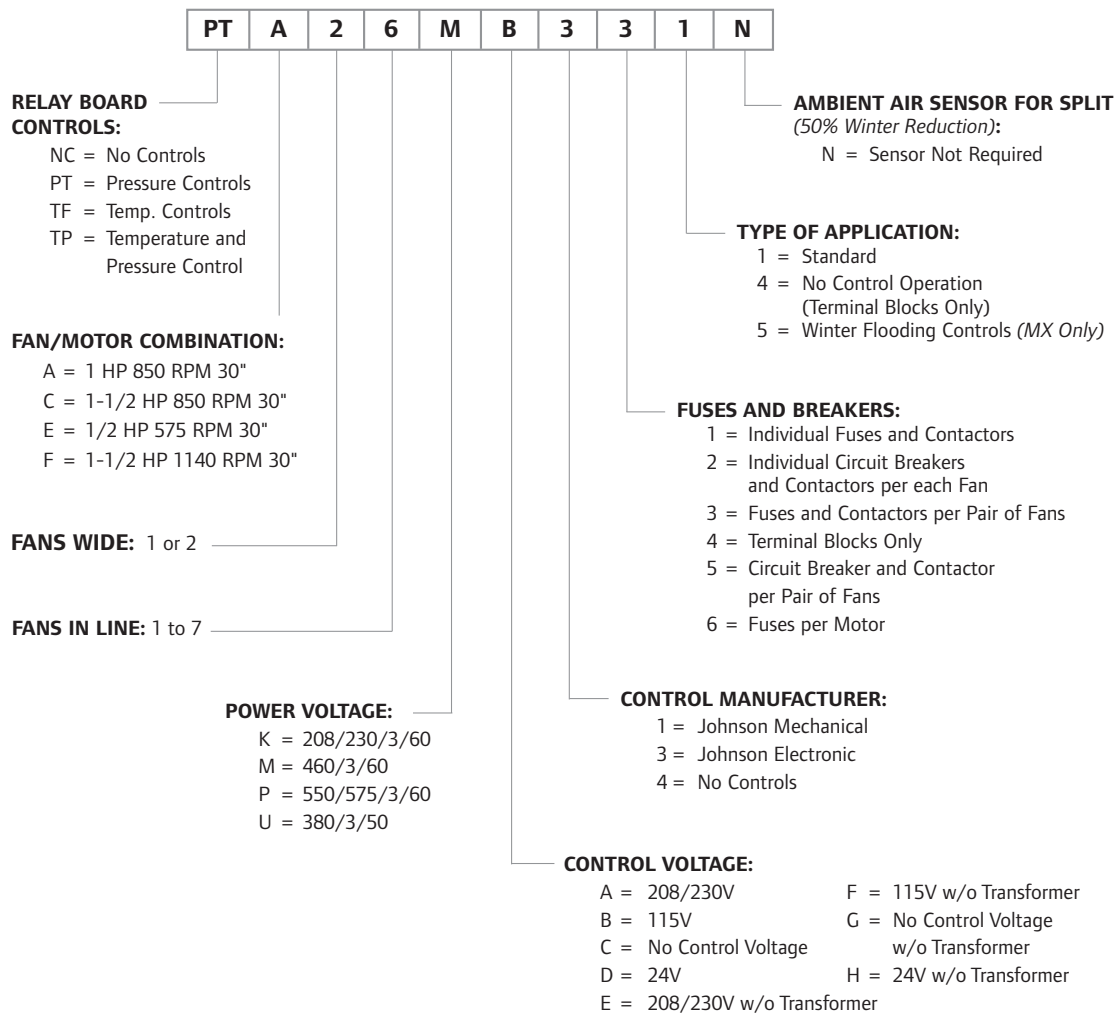

Microchannel Remote Air Cooled Condenser

Condenser Control Panel

Standard Fan Cycling Control Panel Arrangement

- Thermal Fantrol-Electronic temperature control cycles fans in response to entering air temperature. Set points and differential for each step are adjustable.
- Pressurtrol-Electronic pressure control with single point pressure transducer cycles fans in response to condenser pressure. Set points and differential for each step are adjustable.
- Thermal Pressure Fantrol-Electronic temperature control cycle fans in response to entering air temperature, except for control panel end fans. These fans are controlled by pressure.

Control Panel

- Standard weather resistant enclosure is mounted on the right side of the unit when looking at the headers.
- Control power is 24, 115 or 230 volts. A transformer is factory installed when required.
- Fan contactor with branch circuit fuse protection. Each motor or bank of motors protected by fuses.
- Disconnect not included, but may be required to meet local codes.

Optional Arrangements

- Fan motor contactor and fuses only.
- Fan motor contactor and fuses only which operate via a customer specified solid state board. Circuit board is factory mounted and wired.
- Modular winter reduction available on models with 4 or more fans.

FIGURE 1 - Terminal Block Only Wiring Diagrams (NC - C444)

Motors Wired to Terminals Blocks

- Figure 1 shows typical unit wirings to terminal blocks.
- Fan motors are turned on and off by controls outside of the unit by others.

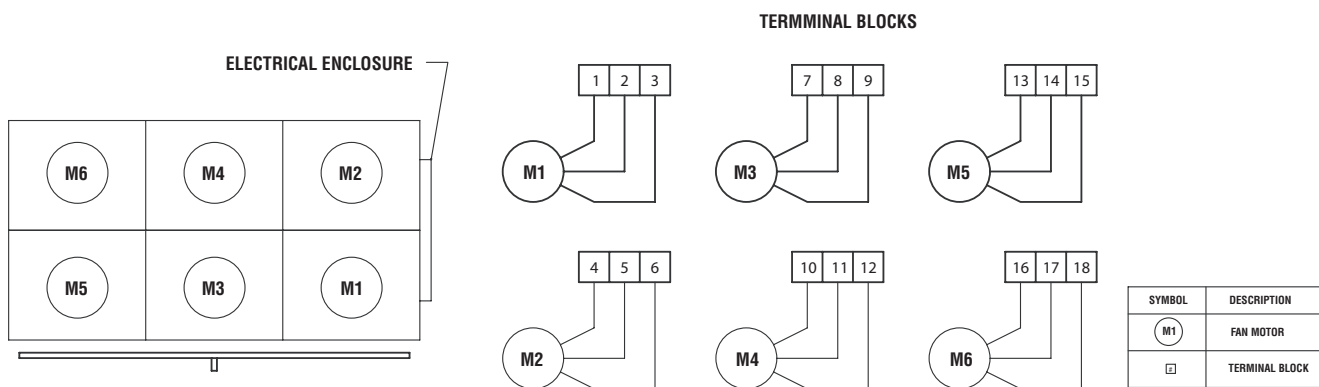

Microchannel Remote Air Cooled Condenser

Condenser Control Panel

FIGURE 2 - Fan Motor Cycling with Individual Fuses and Contactors (-311, -315, -411, -415)

Motors Wired to Standard Fan Cycling Control Panel

- The standard fan cycling control panel for Microchannel units contains a series of pressure or temperature controllers.
- The fans cycle on and off from the signal by the pressure or temperature sensor.
- Fans cycle in pairs, starting at the control panel end of the unit. The header end fan of the first pair is continuously on when the compressor is running. The second fan in this pair cycles and will be the first-on, last-off.
- Figures 2 and 3 have typical wiring schematics.

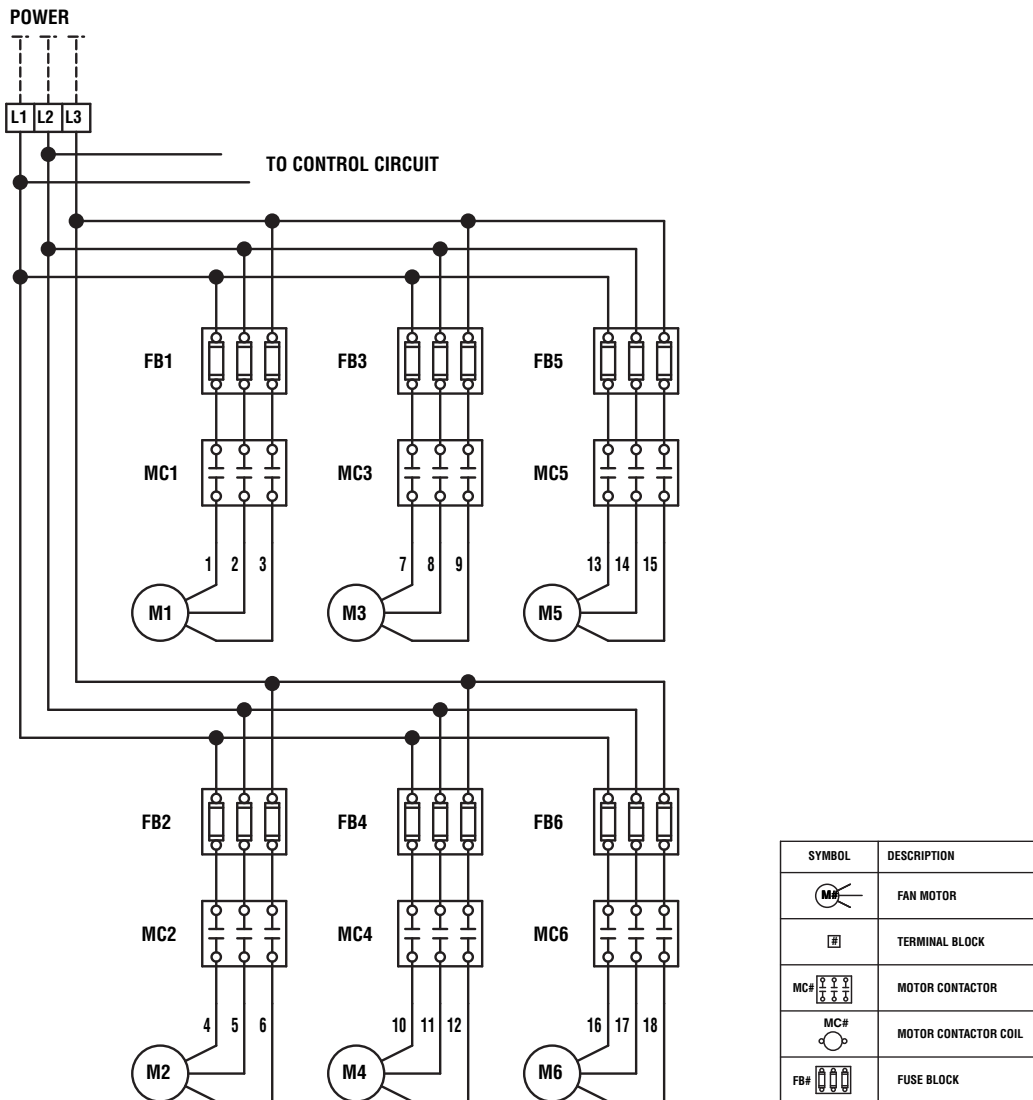

Microchannel Remote Air Cooled Condenser

Condenser Control Panel

FIGURE 3 - Fan Motor Cycling with Fuses and Contactors in Pairs (-331)

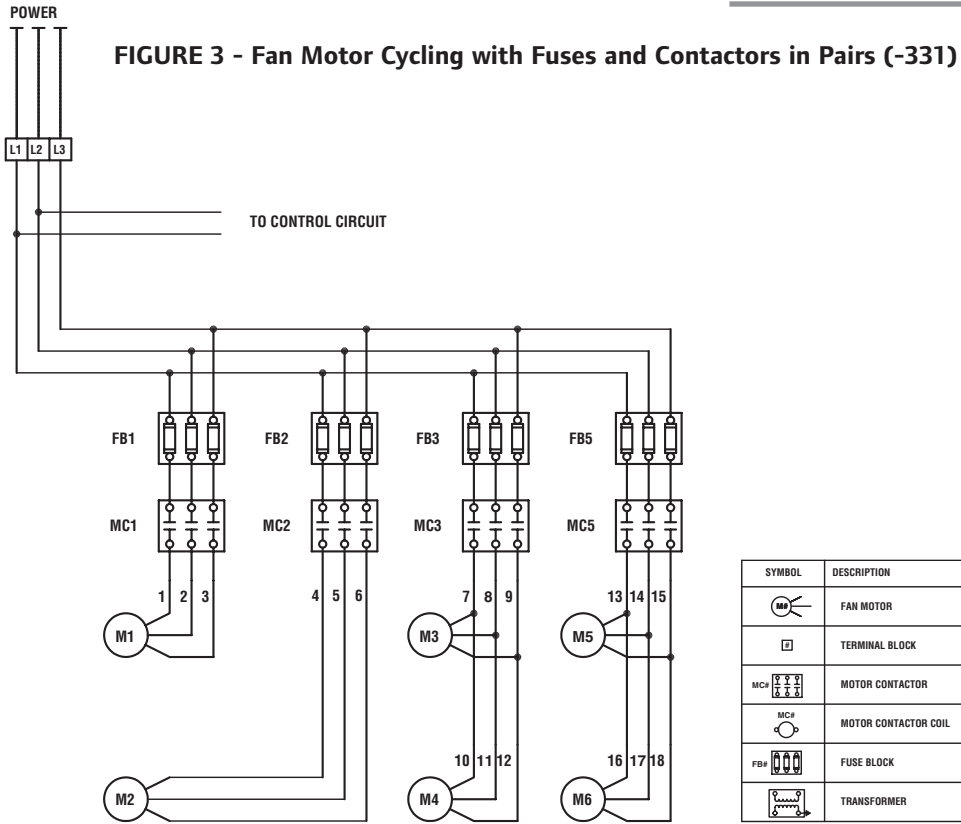

Microchannel Remote Air Cooled Condenser

Condenser Control Panel

FIGURE 4 - Control Circuit Wiring Diagram (-XX5)

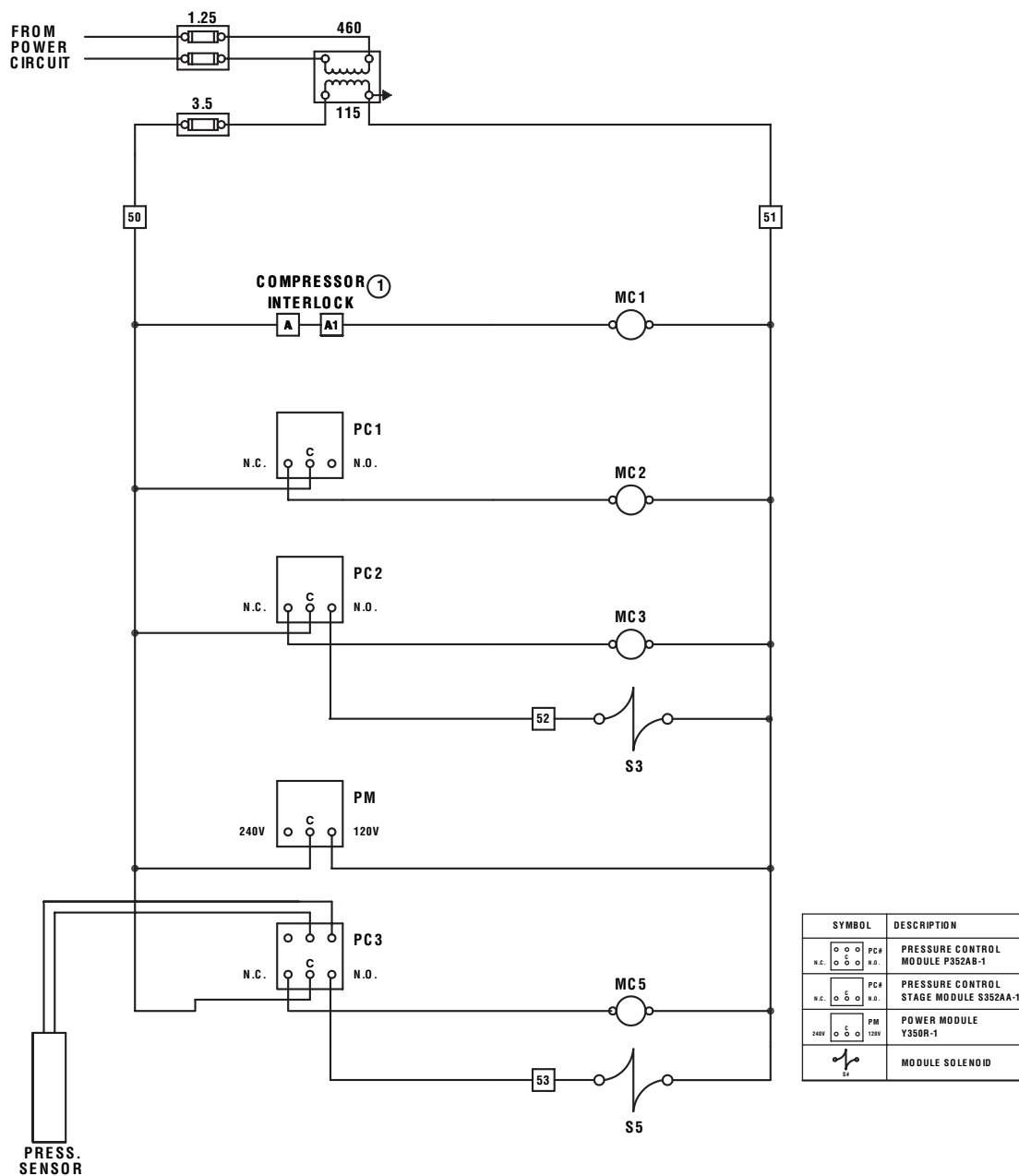

Microchannel Remote Air Cooled Condenser

Replacement Parts

MXA UNIT	
DESCRIPTION	PART #
MOTOR: 1 HP, 850 RPM, 208-230/460/3/60	4410714
MOTOR: 1 HP, 850 RPM, 575/3/60	4410180
FAN: 30" DIA. CW 5/8" BORE	4410710
GUARD: FOR 30" FAN	4910218

MXE UNIT	
DESCRIPTION	PART #
MOTOR: 1/2 HP, 575 RPM, 208-230/460/3/60	4410184
MOTOR: 1/2 HP, 575 RPM, 575/3/60	4410315
FAN: 30" DIA. CW 5/8" BORE	4410709
GUARD: FOR 30" FAN	4910218

MXC UNIT	
DESCRIPTION	PART #
MOTOR: 1-1/2 HP, 850 RPM, 208-230/460/3/60	4410717
MOTOR: 1-1/2 HP, 850 RPM, 575/3/60	4410313
FAN: 30" DIA. CW 5/8" BORE	4780664
GUARD: FOR 30" FAN	4910218

MXF UNIT	
DESCRIPTION	PART #
MOTOR: 1-1/2 HP, 1140 RPM, 208-230/460/3/60	4410718
MOTOR: 1-1/2 HP, 1140 RPM, 575/3/60	4410314
FAN: 30" DIA. CW 5/8" BORE	4410709
GUARD: FOR 30" FAN	4910218

COMMON PARTS	
DESCRIPTION	PART #
MOTOR CONTACTOR WITH 24 VOLT COIL	4480824
MOTOR CONTACTOR WITH 110 VOLT COIL	4481721
MOTOR CONTACTOR WITH 230 VOLT COIL	CALL
P352AB-3C PRESSURE CONTROLLER	4481838
S352AA-2C ADDER MODULE (PRESSURE)	4481839
P399BAC-1C PRESSURE TRANSDUCER	4481840
A350AB-1 TEMPERATURE CONTROLLER	4481731
Y350 R-1 POWER MODULE	4481827
A99BC-300 TEMPERATURE SENSOR (9.75 FEET)	4481813
MOTOR MTG BRACKET - 30" FAN UNIT (2 PER)	4914772
MOTOR MTG RING - 30" FAN UNIT (1 PER)	4910148
STD 22" TAPERED RT SUPPORT LEG - 30" FAN	CALL
STD 22" TAPERED LT SUPPORT LEG - 30" FAN	CALL
STD 30" TAPERED RT SUPPORT LEG - 30" FAN	CALL
STD 30" TAPERED LT SUPPORT LEG - 30" FAN	CALL



Krack Corporation

1300 North Arlington Heights Rd., Suite 130
Itasca, IL 60143
Ph: 630.629.7500

krack.com